

CODE: PLT400P402SP20-100-2DDBJ

Traction motor data

Type: Servo motor (PLT-B130P3000S20-Z)

Power (S2)	W	4000*2
Battery voltage	V (DC)	48
Current	A	100
Speed	rpm	2000
Rated Torque	Nm	19.1
Maximum torque	Nm	47.8
Enclosure	IP	65
Encoder	incremental encoder	
Wheel diameter	mm	400
Gear ratio	I	100
Travel wheel speed	m/min	25
Travel wheel Rated Torque	Nm	1379
Travel wheel peak torque	Nm	2758
Lubrication	Grease	
Max load on vulkollan wheel	Kg	20000
Torsional Angle	°	3
Brake torque	Nm	58
Brake voltage	V (DC)	24
Brake power	W	35

Swing Radius	mm	539
Total weight	Kg	

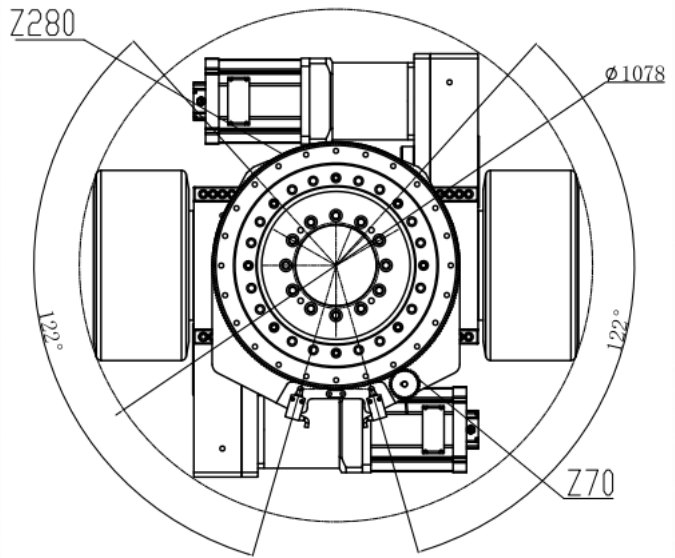
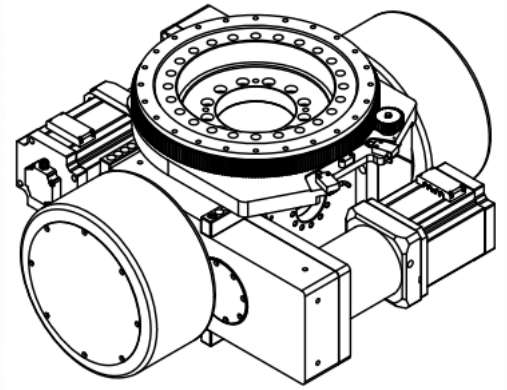
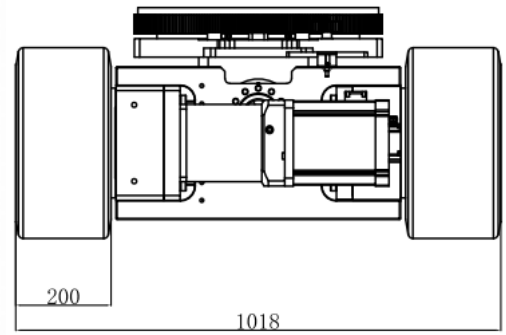
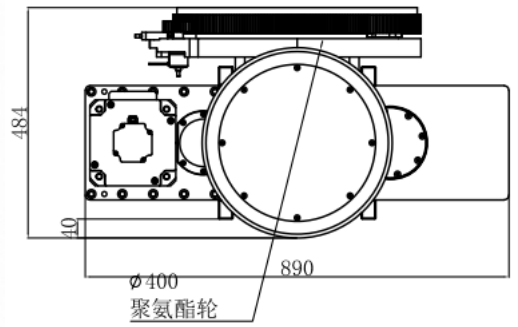

DB15 Male connector

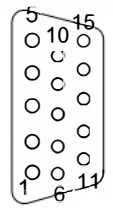

Connector Detail (Power Ring)			Brake wiring	
PIN	CLO	FUNCTION	PIN	SIG
1		U	1	+
2		V	2	-
3		W		
4		PE		

Traction Encoder wiring definition

PIN	1	2	3	4	5	6	7	8	9	10	11	12	13	14	15
SIG	A-	B-	Z-	U-	V-	W-	A+	B+	Z+	U+	V+	W+	+5V	GND	Ov

CO	Shanghai Plutools Automation Equipment Co. Ltd	\\2-1107.png
URL	https://www.plutools.com/	
Drawn:	GBF	Date: 2026. 3. 2
Check:		